

Probe in optimised design for measurement of flow even at very low velocities and also in demanding oncoming flow conditions

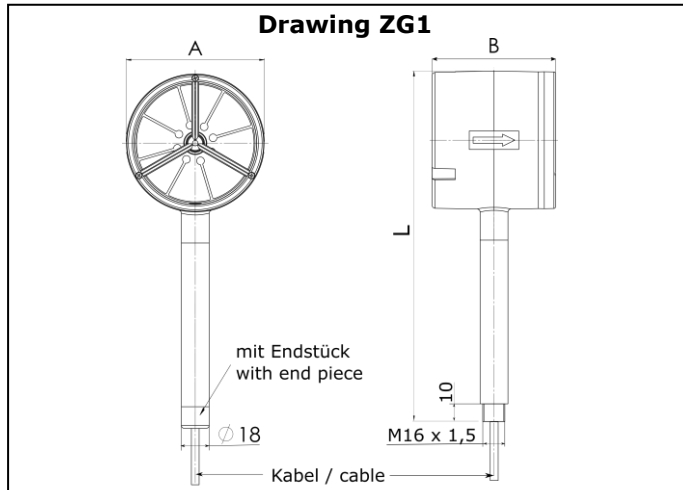

probe: line of sight in flow direction

probe: side view

Measurable variable

- actual flow velocity v [m/s] in air/gases

Measuring ranges

- 0.15 m/s up to 5 m/s
- 0.25 m/s up to 20 m/s
- 0.40 m/s up to 50 m/s

Functional principle

- vane wheel flow sensor
- scanning the vane wheel rotation; non-contact inductive proximity switch

Design

- probe with T-head and direct cable outlet

Medium

- air, clean gases or gas mixtures

Advantages

- low sensitivity to indirect oncoming flow
- low pressure drop thanks to flow-optimised design
- very low starting value
- corrosion resistant
- working temperature range up to +125 °C
- operates to a large extent irrespective of gas density and composition
- extendable
- turndown ratio up to 1 : 125
- optional application in category 2 (zone 1)

Humidity in the gas

- relative gas humidity of less than 100 % does not affect the measurement uncertainty in any way

Range and examples of application

- measuring flow velocity e.g. of air
- vehicle wind tunnel tests
- measuring air flow patterns of components in aircraft
- measurements at workplaces
- measurements in vehicle interior
- measurements on ventilation and air conditioning systems
- net measurements on large inlets and outlets
- aerodynamic investigations
- measurement of laminarflow
- air stream fan

Particles in the medium

- can cause restriction in the fatigue strength of the vane wheel set

Model designation (example)							
TS	90/80	G	ZnAl	mk20A	140	p0	ZG1
(1)	(2)	(3)	(4)	(5)	(6)	(7)	(8)

Basic types		
Type	Measuring range details see under (5)	Article No.
TS90/80 GZnAl-mk5A/140/p0/ZG1	max. 5 m/s	B008/159
TS90/80 GZnAl-mk20A/140/p0/ZG1	max. 20 m/s	B008/160
TS90/80 GZnAl-mk50A/140/p0/ZG1	max. 50 m/s **	B008/161

(1) Sensor type	
Vane wheel flow sensor with T-head	
TS	: T-probe

(2) Sensor dimensions (see drawing ZG1, page 1)				
Type	Sensor head diameter A [mm]	Sensor head length B [mm]	Shaft Diameter [mm]	Sensor length L (w/o end piece) [mm]
... 90/80 ...	90	80	18	225

(3) Medium	
... G ...	air / gases

Ingress protection cable outlet	
Sensor design ... G ...	IP50

(5) Materials in contact with the medium	
Design	Material
... ZnAl ...	zinc alloy, stainless steel shaft, aluminium vane wheel, epoxy resin, polysulfone, ceramics, ...

(5) Measuring ranges (with a gas density of approx. 1.2 kg/m ³) / vane wheel type; if the vane wheel material differs from that of the sensor, the vane wheel type has a material abbreviation (e.g. „A“ for mk20A)			
sensor material	vane wheel material	vane wheel type	Measuring ranges air/gases
Zinc alloy	aluminium	mk5A mk20A mk50A	0.15 ... 5 m/s 0.25 * ... 20 m/s 0.40 * ... 50 m/s**

* possibly deviating for flow from standstill (zero flow / alignment)

** can be used for a short time up to 10 % above maximum value

(5) Measuring ranges / Calibration / Measurement uncertainty (cont.)

with a gas density of approx. 1.2 kg/m³, see Basic types, Page 2

DAkKS Calibration		
Description	Article no.	
6 calibration values in the measuring range up to 40 m/s	CV-40 DAKKS	
6 calibration values in the measuring range up to 70 m/s	CV-70 DAKKS	
DAkKS calibration certificate (mandatory)	KLB	
Measurement uncertainty	< 0.9 % of measured value + 0.25 % of terminal value	with linearisation of characteristics (pairs of values, see doc. U183)
Repeatability	±(0.05 % of measured value + 0.02 m/s)	

ISO Calibration		
Description	Article no.	
standard calibration		
ISO calibration certificate (optional)	KLB	
Measurement uncertainty	< 1.5 % of measured value + 0.5 % of terminal value	
Repeatability	±(0.05 % of measured value + 0.02 m/s)	

(6) Permissible temperature of the medium

Design	
... 140 ...	-20 ... +125 °C (short-time up to +140 °C)

(7) Max. working pressure

... p0 ...	only atmospheric applications
------------	-------------------------------

(8) Design (see page 1)

Drawing ZG1	probe for max. +125 °C with 2 m cable with direct outlet for max. +105 °C, cable socket (order related)
--------------------	----------------------------------------------------------------------------------------------------------------------

Output

Sensor	separate Höntzsch unit for signal evaluation:
TS : v/FA	transducer UFA, hand-held unit flowtherm NT.2, hand-held unit flowtherm Ex, system unit µP-ASD ...

Option 'Ex-protection'		
Type of protection	Article no.	Remark
CE <Ex> II 3 G Ex ec IIC T6 Gc X gas-Ex: category 3G (zone 2)	FAEX2E *	in conjunction with evaluation unit
CE <Ex> II 3 D Ex tc IIIC TX Dc X dust-Ex: category 3D (zone 22)	FAEX2E *	in conjunction with evaluation unit
CE <Ex> II 2 G Ex ia IIC T6 Gb gas-Ex: category 2G (zone 1)	FAEX1 *	only in conjunction with: - isolation-/supply unit LDX2 <u>and</u> 'non-Ex evaluation unit' or - ATEX-conform, separate evaluation unit with v/FA-Ex input

* remark: media and ambient temperature according to the valid operating instructions

Evaluation unit connection		
for unit with 8-pin screw-type connector		
plug 423-8*	type of protection IP67	Article no.. A099/056
plug 680-8*	type of protection IP40	A099/055
plug LEMO.0-4	with extension rods VS18 ... incl. LEMO.0-4 / 423-8 adapter cable	A099/078
for unit with connecting terminals		
stripped cable end	marked strands with end sleeves	A099/110

* with extension rods VS18 ... please use article no. A099/078 or A099/110

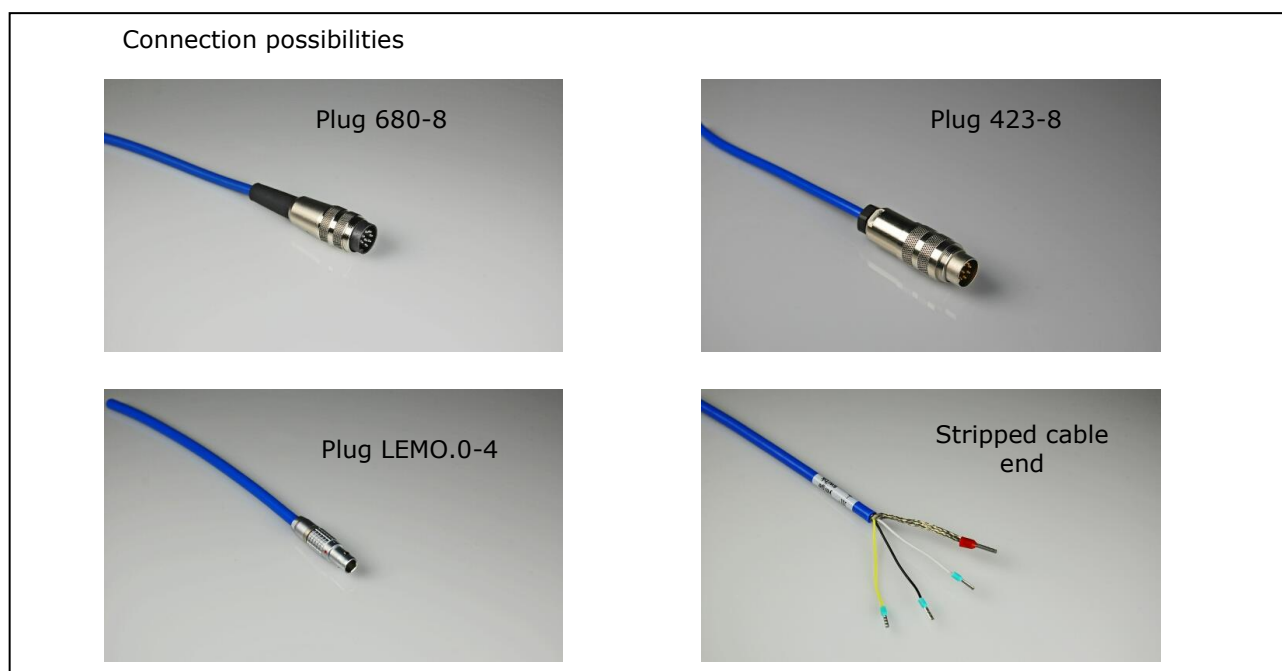

Accessories		
	Description	article no.
VS18E-350	extension rod, stainless steel, 350 mm length	B099/002
RZ18	direction indicator RZ18	B099/951

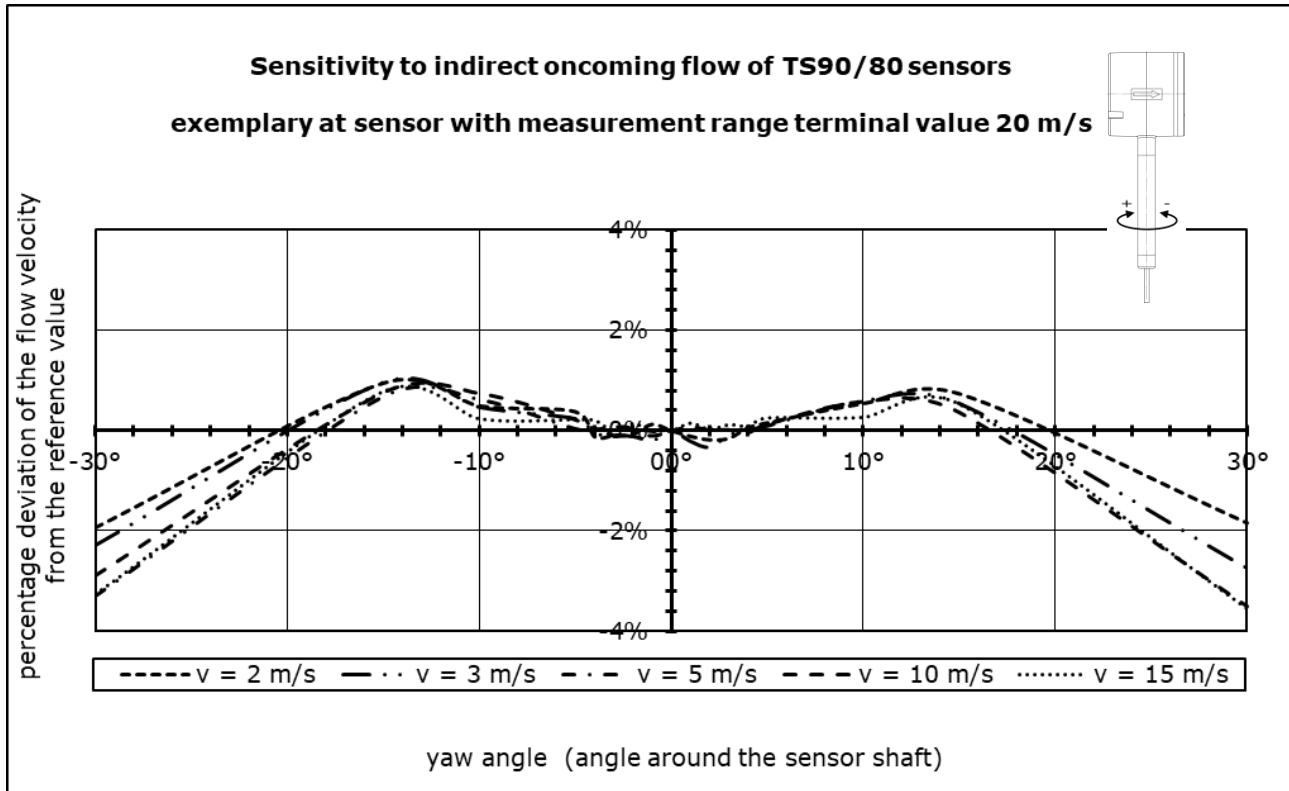

Höntzsch GmbH & Co. KG
 Gottlieb-Daimler-Straße 37
 D-71334 Waiblingen
 Telefon +49 7151 / 17 16-0
 E-Mail info@hoentzsch.com
 Internet www.hoentzsch.com

Subject to alteration