

Probe VA(T)40 ZG4 with flange probe guide piece SFB

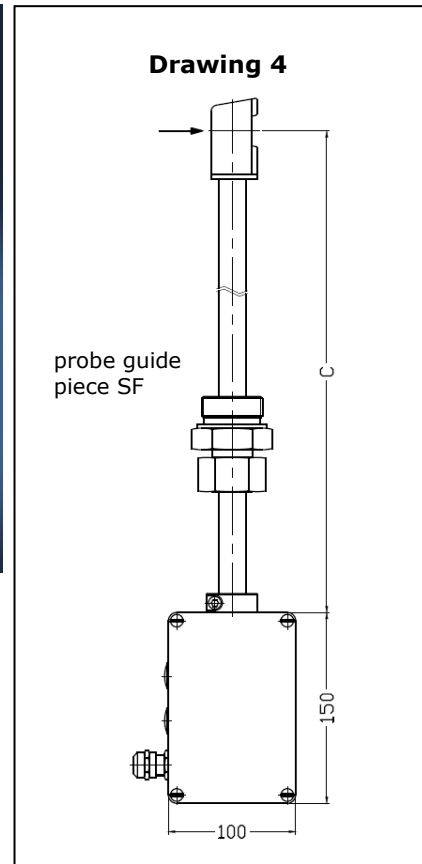

Probe with screw thread probe guide piece SF

Functional principle

- vortex meter for measuring flow velocity, flow rate and volume
- ultrasonic measurement of the vortex shedding



Kármán vortex street

Design

- insertion probe with probe guide piece and AS102 housing; optional with integrated transducer

Measured variables

- actual flow velocity v [m/s]
- actual flow rate [m³/h]
- conversion to standard velocity/standard volume flow with input parameters pressure and temperature

Measuring range

- 0.5 ... 40 m/s

Medium

- primarily single-phase gas mixtures, e.g. air, nitrogen, oxygen, methane, natural gas, ammonia, argon, carbon monoxide, superheated steam, biogas, exhaust gas, etc.
- other gases or gas mixtures on request

Advantages

- compact unit with optional integrated transducer
- optional with LCD-display in non-hazardous area
- also connectable to different separate transducers
- optional with integrated temperature measurement
- modular design with different sensor- and sealing materials
- various probe guide pieces usable
- with isolation/supply unit for use in category 1 (zone 0 and zone 20)
- low starting value (0.5 m/s)
- high turndown ratio (1 : 80)
- long-term stability
- no moving parts
- easy to clean
- high durability
- corrosion-resistant
- largely unaffected by gas composition
- marginal pressure loss

Range and examples of application

- flow measurement in explosive atmospheres: air, outlet air, sludge activation air, engine intake air, natural gas, exhaust gas, process gas, biogas, car exhaust emissions, flare gas, overheated steam, ...

Particles, humidity and condensation

- dust or fibre particles in the gas do not affect the measurement, as long as these are not abrasive or accumulate on the sensor
- measurement uncertainty remains unaffected by a relative gas humidity of less than 100 % and a slight accumulation of condensate on the sensor

Model designation (example)					
VA40/21,3	G	E	40 m/s	p3	ZG4
VAT40/21,3	G	E	40 m/s	p3	ZG4
(1)	(2)	(3)	(4)	(5)	(6)

Types	
Type	Article No.
VA 40/21,3 GE 40 m/s p3 ZG4	B009/400
VA 40/21,3 GH 40 m/s p3 ZG4	B009/406
VA 40/21,3 GT 40 m/s p3 ZG4	B009/410
VAT 40/21,3 GE 40 m/s p3 ZG4	B009/450
VAT 40/21,3 GH 40 m/s p3 ZG4	B009/456
VAT 40/21,3 GT 40 m/s p3 ZG4	B009/460

(1) Sensor type / Sensor diameter	
VA 40/21,3	Vortex flow sensor VA40 with sensor head width across corners 40 mm and shaft \varnothing 21.3 mm for insertion in openings with a diameter greater than 40 mm
VAT 40/21,3	like above, but with additional integrated PT100 temperature sensor

(2) Medium	
... G ...	air / gases

(3) Materials in contact with the medium	
Design	Material
... E ...	stainless steel, sensor housing 1.4581, connection tube 1.4404, ceramics, silicone-free sensor
... H ...	Hastelloy 2.4610 / HC4, ceramics, silicone-free sensor
... T ...	titanium 3.7035 (grade 2), ceramics, silicone-free sensor

(4) Measuring range	
Design	Measuring range
... 40 m/s ...	0.5 ... 40 m/s
Measurement uncertainty*	< 1.0 % of measured value + 0.03 m/s
Repeatability*	\pm 0.2 % of measured value + 0.025 % FS
* Only for versions with pairs of values with linearization of characteristics; by use of the KKZ-function other specifications are possibly valid	

Examples of measurable flow rates (s. also under '(4) Measuring range', Page 2)

measuring tube inside diameter Di [mm]	profile factor PF* [-]	smallest measurable value [m³/h]	terminal value [m³/h]
80	0.719	6.5	520
100	0.738	10.4	835
120	0.761	15.5	1240
150	0.796	26	2030
200	0.842	48	3810
300	0.845	108	8600
400	0.850	193	15400
500	0.860	304	24300
750	0.860	684	54700
1000	0.860	1215	97300
1250	0.860	1900	152000
1500	0.860	2735	218800

Flow rate measuring range specifications with centric positioning of sensor, non-rotational (vortex-free) inlet flow and amply dimensioned input/output sections (see 'Information for use VA Probes' U206).

* The profile factor PF describes the ratio of average flow velocity in the measurement cross section and the flow velocity measured from the sensor. The aforementioned operating conditions apply.

Working temperature / seal material

Temperature class of the sensor	Material	working temperature range of medium	Article No.
100 °C	FKM (standard)	-20 ... +100 °C	B009/080
	Silicone	-40 ... +100 °C	B009/081
	EPDM	-40 ... +100 °C	B009/082
	KALREZ® 4079	0 ... +100 °C	B009/083
	KALREZ® 6375	0 ... +100 °C	B009/085
	PFA	-20 ... +100 °C	B009/084
180 °C	FKM (standard)	-20 ... +180 °C	B009/090
	Silicone	-40 ... +180 °C	B009/091
	EPDM	-40 ... +160 °C	B009/093
	KALREZ® 4079	0 ... +180 °C	B009/092
	KALREZ® 6375	0 ... +180 °C	B009/095
	PFA	-20 ... +180 °C	B009/094
240 °C	FKM (standard)	-20 ... +240 °C	B009/097
	PFA	-20 ... +240 °C	B009/098

* When used in hazardous areas, the media and ambient temperature are limited according to the valid operating instructions

Permissible ambience temperature *

with integrated transducer UVA, w/o display	-25 ... +60 °C
with integrated transducer UVA, with option LCD-Display	-25 ... +60 °C
without integrated transducer UFA	-5 ... +60 °C

* When used in hazardous areas, the media and ambient temperature are limited according to the valid operating instructions

(5) Maximum working pressure

up to 3 bar / 300 kPa overpressure

(6) Design

as in drawing 4 (Page 1)

Installation length (see Drawing ZG4, Page 1)

Measurement C	for sensor in design		
	stainless steel '... E ...'	Hastelloy '... H ...'	titanium '... T ...'
	Article No.	Article No.	Article No.
250 mm	B009/050	B009/060	B009/070
500 mm	B009/051	B009/061	B009/071
750 mm	B009/052	B009/062	B009/072
1000 mm	B009/053	B009/063	B009/073
1250 mm	B009/054	B009/064	B009/074
1500 mm	B009/055	B009/065	B009/075
1750 mm	B009/056	B009/066	B009/076
2000 mm	B009/057	B009/067	B009/077

Select the installation length so that the surface temperature of the transducer housing does not exceed +50 °C!

Connection housing AS102

Dimensions	L/W/H: 100/80/150 mm
Material	die-cast aluminium G Al Si12 / DIN 1725
Protection class	IP65, IEC 529 and EN 60 529
Connection	bush for shielded cables with external diameter 5 ... 10 mm, contacting of the overall copper shielding by the metallic screwed cable glands

Electromagnetic Compatibility (EMC)

according to EN 61 000-6-2 and EN 61 000-6-4

Installation position

any	horizontal positioning is recommended if condensate on the sensor cannot be ruled out
-----	---

Option ATEX-protection

type of protection	Comment	Article No.
for gas: CE <Ex> II 1/2 G Ex ia IIC T6 Ga/Gb Categorie 1/2G (zone 0/1) for dust: CE <Ex> II 1/2D Ex ia IIIC TX Da/Db Categorie 1/2D (zone 20/21)	only in conjunction with: <ul style="list-style-type: none"> Isolation/supply unit LDX2 and 'non-Ex evaluation unit' or compatible separate evaluation unit with Ex-input (see below) 	VAEX0 * excluded are: <ul style="list-style-type: none"> - VAT-sensors - temperature of medium less than -20 °C - titanium sensors
CE <Ex> II 3 G Ex ec IIC T6 Gc X CE <Ex> II 3 D Ex tc IIIC TX Dc X	Category 3G (zone 2) Category 3D (zone 22)	VAEX2E *

* remark: media and ambient temperature according to the valid operating instructions

Output v/VA, v/VA-Ex, 4-20 mA or 0-10 V

output sensor v/VA	Höntzsch evaluation unit ** with v/VA input is necessary for signal interpretation
output sensor v/VA-Ex, (sensor mit 'type of protection Ex-i', see above)	Höntzsch evaluation unit** with intrinsically safe input v/VA-Ex or an evaluation unit with input v/VA together with a series connection isolation/supply unit LDX2 is necessary for signal interpretation
output 4-20 mA <u>or</u> 0-10 V	with transducer UVA integrated in the connection housing (see below)
** e. g. UVA, µP Vortex, VT-VA, VP-VA or VTP-VA	

optional transducer UVA, integrated in the sensor connection housing

(please select)	Description	Article No.
UVA / 4-20 mA / 24 VDC	analog output flow 4 ... 20 mA resistance max. 400 Ohm	A016/002-S01
UVA / 0-10 V / 24 VDC	analog output flow 0 ... 10 V impedance max. 1 kOhm	A016/005-S01
output temperature (only for VAT sensors)	analog output temperature 4 ... 20 mA resistance max. 200 Ohm Scaling is permanently set at the factory according to customer requirements and cannot be changed.	A016/000
output limit value or quantity pulse	potential-free relay contact (normally open contact), max. 300 mA / 27 VDC	
PC interface	RS232	
	output signals are electrically isolated from the power supply	
self-monitoring	parameter settings, sensor interface; in case of error: analog output less than 3.6 mA or <-0.2 V	
connection	'push in' PCB terminals; no tools necessary for strand connection; disconnect strands by applying pressure with a pen or screwdriver; for strands with cross-section 0.14 ... 1.5 mm ²	
power supply	24 V DC (20 ... 27 V DC)	
power consumption	less than 5 W	
setting parameter	analog output, time constant, profile factor, tube inside diameter, limit value or quantity pulse (quality rating adjustable), switch from actual/standard flow with setting parameters 'working pressure' and 'working temperature'	
	setting parameter with PC software UCOM and PC connection cable (see Accessories) alterable	

**compatible separate evaluation units
(necessary in conjunction with sensors VA40/21,3 ... ZG4 and VAT40/21,3 ... ZG4 without integrated transducer UVA)**

for non-Ex applications	UVA, µP-Vortex, VT-VA, VP-VA, VTP-VA
for Ex applications	isolation/supply unit LDX2 in LDG16 housing in combination with evaluation units UVA, µP-Vortex, VT-VA, VP-VA, VTP-VA in LDG housings (additional requirement: Ex-input t, p)

Accessories (optional)		
	Description	Article No.
LCD in housing cover*°	row 1: 'instantaneous value': flow rate or flow velocity row 2: 'quantity counter' or 'error code'; 2 x 16 digit, character height 5.5 mm working temperature range -25 ... +60 °C	A010/016
Calibration certificate		KLB
PC software UCOM*°	for configuring transducers UFA and UVA via RS232 interface, PC connection cable RJ22 / sub-D 9-pin additional requirement	A010/052
PC connection cable RJ22 / sub-D 9-pin*°	for configuring transducers UFA and UVA in LDG16 or AS102 housing via RS232 interface together with UCOM software; transducer connection: RJ22 PC connection: sub-D 9-pin	A010/051
Interface converter*° USB / RS232	for connecting PC to USB port and Höntzsch programming adapter to RS232 interface; PC connection: USB plug type A prog. adapter connection: sub-D 9-pin	A010/100

*° only in conjunction with integrated transducer UVA (see above)

Probe guide pieces* (see also Page 8)						
Model designation (examples)						
SFB	21.3		E	53	G1 1/2"	ZG5
SFK	21.3	/42	E	150	F-DN50PN16	ZG3
(S1)	(S2)	(S3)	(S4)	(S5)	(S6)	(S7)

(S1) Type	
SFB	SF with clamping bush
SFK	SF with clamping yoke
SFZ	SF with collet
(S2) Diameter through hole [mm]	
... 21.3 ...	21.3 mm through hole
(S3) Diameter insertion opening for probe	
(S4) Material	
... E ...	stainless steel
... H ...	Hastelloy
(S5) Installation length L [mm]	
(S6) Process connection	
... G ...	thread
... F ...	flange
(S7) Design as in Drawing (ZG)	

Probe guide pieces* (cont'd)		
Type	Description	Article No.
with screw thread connection		
SFB 21.3 E-53 / G 1 1/2" according drawing 5 (see page 8)	connection: outside thread G 1 1/2" max. pressure: 3 bar / 300 kPa temperature: -20 ... +240 °C materials: stainless steel, FKM, PTFE fixation: clamping bush length: 53 mm thread length: 22 mm	B004/504
SFB 21.3 E-53 / G 1 1/2" with metallic sealing according drawing 5 (see page 8)	connection: outside thread G 1 1/2" max. pressure: 3 bar / 300 kPa temperature: -40 ... +240 °C materials: stainless steel, PTFE fixation: clamping bush length: 53 mm thread length: 22 mm	B004/511
SFB 21.3 E-53 / NPT 1 1/2" according drawing 5 (see page 8)	connection: outside thread NPT 1 1/2" ANSI/ASME B1.20.1-1983 max. pressure: 3 bar / 300 kPa temperature: -20 ... +240 °C materials: stainless steel, FKM, PTFE fixation: clamping bush length: 53 mm thread length: 26 mm	B004/509
with flange connection		
SFB 21.3 E-70 / F-DN50 PN16 according drawing 1 (see page 8)	connection: flange DN50 PN16 EN1092-1 max. pressure: 3 bar / 300 kPa temperature: -40 ... +240 °C materials: stainless steel, PTFE fixation: clamping bush length: 70 mm	B004/103
SFB 21.3 H-70 / F-DN50 PN16 according drawing 1 (see page 8)	connection: flange DN50 PN16 EN1092-1 max. pressure: 3 bar / 300 kPa temperature: -40 ... +240 °C materials: Hastelloy, PTFE fixation: clamping bush length: 70 mm	B004/105
SFB 21.3 E-70 / F-ANSI 2" 150 lb RF according drawing 1 (see page 8)	connection: flange 2" 150 lbs ANSI B16.5 max. pressure: 3 bar / 300 kPa temperature: -40 ... +240 °C materials: stainless steel, PTFE fixation: clamping bush length: 70 mm	B004/512
SFK 21.3 / 42 E-150 / F-DN50 PN16 with ball valve DN50 PN16 similar to drawing 3 (see below)	connection: flange DN50 PN16 EN1092-1 max. pressure: 6 bar / 600 kPa temperature: -20 ... +240 °C materials: stainless steel, 2 FKM O-rings fixation: clamp yoke length: 150 mm (ball valve) length: 155 mm (probe guide piece) Accessory: hexagon cranked wrench key SW5 The probe can be retracted into the probe guide piece to close the ball valve.	B004/313

Probe guide pieces* (cont'd)		
Type	Description	Article No.
SFK 21.3 E-150 / F-DN50 PN16 according drawing 3 (see below)	connection: flange DN50 PN16 EN1092-1 max. pressure: 6 bar / 600 kPa temperature: -20 ... +240 °C materials: stainless steel, FKM O-ring fixation: clamp yoke length: 150 mm Accessory: hexagon cranked wrench key SW5	B004/304

* Probe guide pieces are obligatory for process connection via screw socket or flange connector. They are adjustable, rotatable and permanently attached to the probe shaft. It is to be ensured that sensor length, screw socket or flange connector height as well as probe insertion depth match up. Other probe guide pieces are available on request.

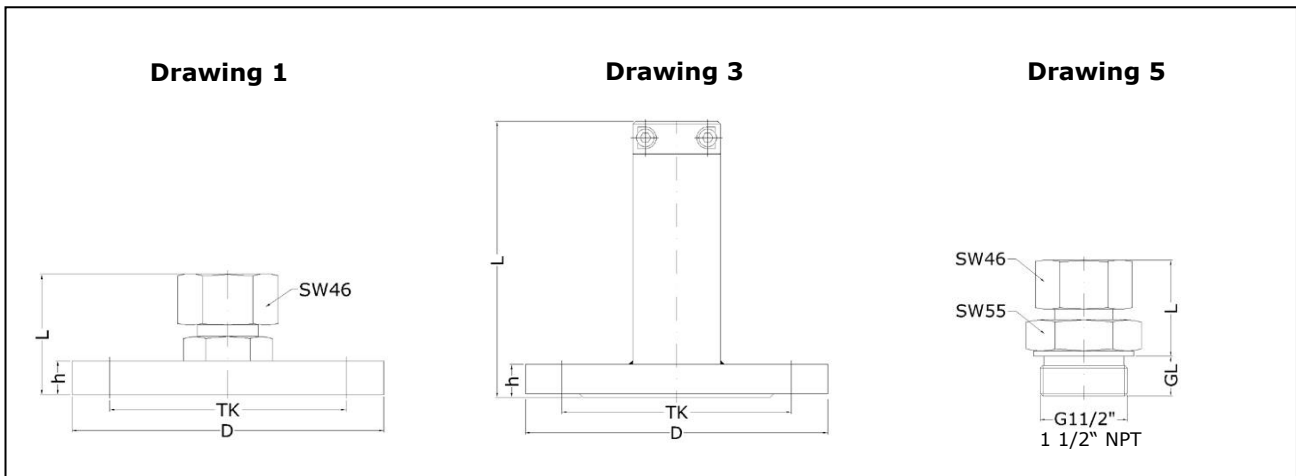

Probe guide pieces SF

Probe installation

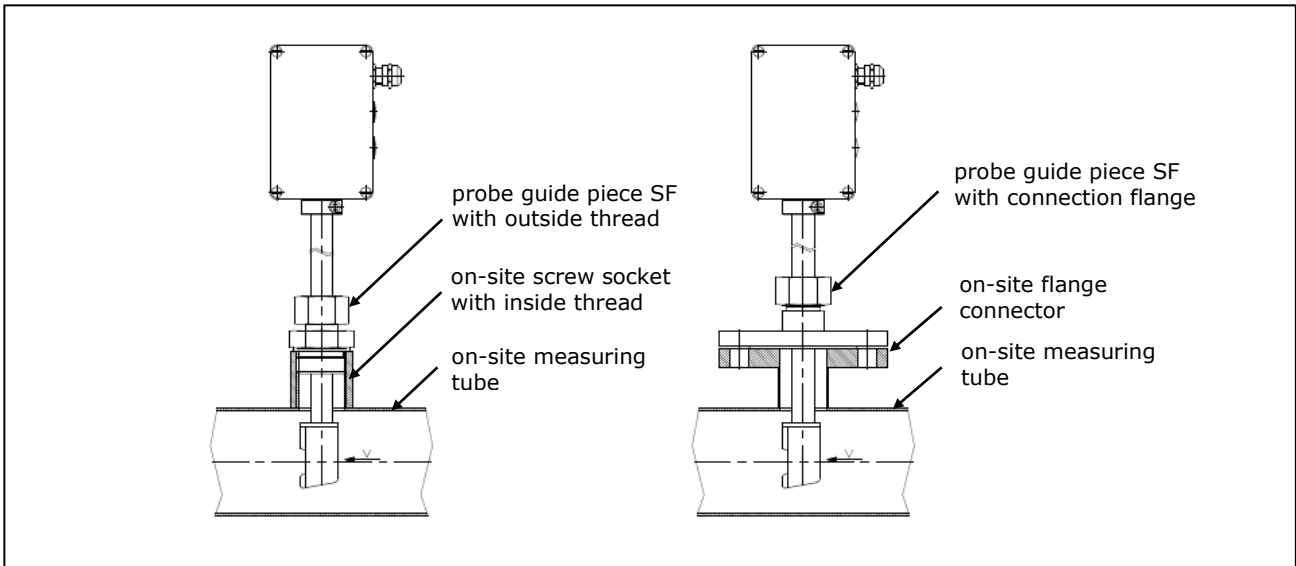

Probe installation with screw thread probe guide piece (left) and flange probe guide piece

Höntzsch GmbH & Co. KG

Gottlieb-Daimler-Straße 37
 D-71334 Waiblingen
 Telefon +49 7151 / 17 16-0
 E-Mail info@hoentzsch.com
 Internet www.hoentzsch.com

® : Registered trademarks
 of DuPont

Subjects to alteration