

**Vortex flow sensor VA40 ... ZG7 with integrated transducer UVA, capable of parameterization**

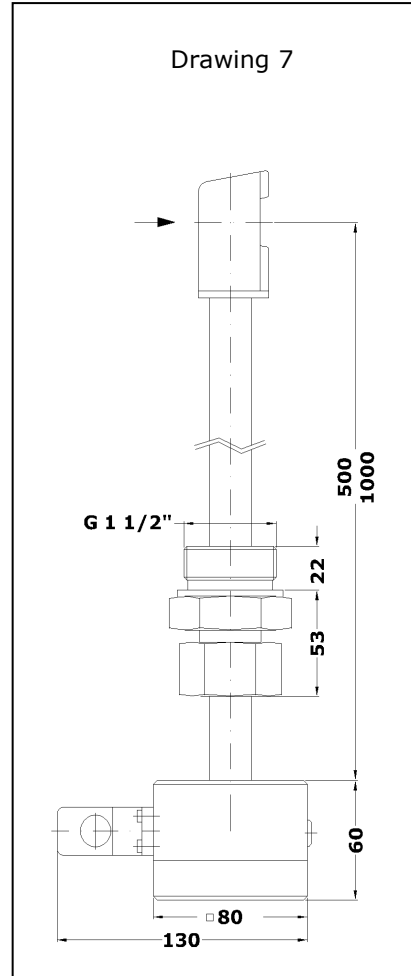

Vortex Flow Sensor VA40

**Measurable variable**

- actual flow velocity  $v$  [m/s] and
- actual flow rate [m<sup>3</sup>/h] in air/gases
- conversion to standard velocity/standard volume flow rate by input parameter working pressure and temperature

**Measuring range**

- 0.5 ... 40 m/s

**Functional principle**

- vortex meter for measuring flow velocity, flow rate and volume
- ultrasonic measurement of the vortex shedding

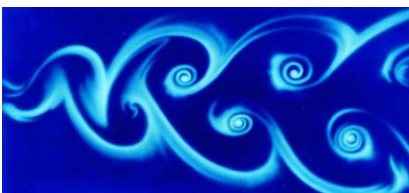

Kármán vortex street

**Design**

- insertion probe with probe guide piece and AS80 housing

**Medium**

- primarily single-phase gas mixtures, e.g. air, nitrogen, oxygen, methane, natural gas, ammonia, argon, carbon monoxide, superheated steam, biogas, exhaust gas, etc.
- other gases or gas mixtures on request

**Advantages**

- small starting value (0.5 m/s)
- high measuring dynamics (1 : 80)
- no moving parts
- high time yield
- corrosion resistant
- operates largely irrespective of the gas composition
- minor pressure drop
- application in Ex-protection Category 3G and 3D (zone 2 and zone 22) permissible
- applications up to SIL2/SC3

**Range and examples of application**

- flow measurement, for example, of air, outgoing air, sludge activation air, engine intake air, natural gas, exhaust gas, process gas, biogas, vehicle engine exhaust gas, flare gas

**Particles, humidity and condensation**

- charges in the gas caused by particles such as dust and fibres do not affect the measurement, as long as abrasion and agglomeration do not occur on the sensor
- relative gas humidity of less than 100 % does not affect the measuring uncertainty
- slight condensation adsorption on the sensor does not affect the measurement

Model designation (example)							
<b>VA40/21.3</b>	<b>-500</b>	<b>G</b>	<b>E</b>	<b>40 m/s</b>	<b>100</b>	<b>p3</b>	<b>ZG7</b>
(1)	(2)	(3)	(4)	(5)	(6)	(7)	(8)

Types		Article No.
Type		
VA40/21.3 -250 GE 40 m/s 100 / p3 ZG7		B009/708
VA40/21.3 -500 GE 40 m/s 100 / p3 ZG7		B009/710
VA40/21.3 -1000 GE 40 m/s 100 / p3 ZG7		B009/711
VA40/21.3 -250 GE 40 m/s 180 / p3 ZG7		B009/714
VA40/21.3 -500 GE 40 m/s 180 / p3 ZG7		B009/712
VA40/21.3 -1000 GE 40 m/s 180 / p3 ZG7		B009/713

**(1) Sensor type / Sensor diameter**  
 Vortex flow sensor VA40 with sensor head width across corners 40 mm and shaft Ø 21.3 mm for insertion in openings with a diameter greater than 40 mm

**(2) Sensor length (see Drawing/Page 1)**  
 250 / 500 / 1000 mm

**(3) Medium**  
 ... G ... air / gases

**(4) Materials in contact with the medium**

Design	Material
... E ...	stainless steel, sensor housing 1.4581, connection tube 1.4404, ceramics, gaskets: FKM, sensor silicone-free

**(5) Measuring range**

Design	Measuring range
... 40 m/s ...	0.5 ... 40 m/s
Measuring uncertainty	< 1.0 % of meas. value + 0.03 m/s
Repeatability	± 0.2 % of meas. value + 0.025 % of full scale

**Examples for measurable volume flows see Table/Page 4**

**(6) Permissible temperature of the medium**

Design	Temperature
... 100 ...	-20 ... +100 °C (continuous)
... 180 ...	-20 ... +180 °C (continuous)

**Permissible ambient temperature (Connection housing AS80, see page 3)**

Design	Ambient temperature
without options: - 'ATEX Cat. 3G and 3D' (page 3) - 'LCD'	-40 ... +60 °C
with option 'LCD'	-5 ... +60 °C
with option 'ATEX Cat. 3G and 3D', (page 3)	-40 ... +60 °C

**(7) Max. working pressure / sensor protection**  
 up to 3 bar / 300 kPa above atmospheric  
 ingress protection IP68

**(8) Design**  
 as in Drawing 7 (see Page 1)

**Connection housing AS80**

measurements	80 / 80 / 60 mm (L / W / H)
connection	connector GO 070 with terminal screws
terminal connections	see Page 4
type of protection	IP65

**Process connection**

with probe guide piece SFB 21.3 E-53 / G 1½" ZG5, insertion depth variable, for connecting to screw socket or ball valve with inside thread G 1½". Probe fixed by clamping bush. Ball valve can only be closed after the probe has been removed.

connection thread	outside thread G 1½", threaded length approx. 22 mm, outside thread NPT 1½" upon request
installation length	approx. 53 mm
through hole	21.3 mm
material	stainless steel
gasket	FKM, PTFE clamping bush

**Design - Transducer UVA, integrated in the sensor connection housing**

analog output flow / burden	4 ... 20 mA * max. 400 Ohm
output limit value	open collector / max. 50 mA / max. 27 V DC
PC interface	RS232
self-monitoring	the output signals are electrically isolated from the power supply parameter settings, sensor interface; in case of error: analog output less than 3,6 mA
connection	connector GO 070 with terminal screws, for connection cable diameter 4 ... 10 mm and lead diameter 0.14 ... 0.5 mm <sup>2</sup>
power supply	24 V DC (20 ... 27 V DC)
power consumption	less than 3 W
working temperature range	-40 ... +60 °C
housing	sensor connection housing AS80
EMC	EN 61 000-6-2 and EN 61 000-6-4
setting parameter	analog output, time constant, profile factor/coefficient, tube inside diameter, limit value or impulse of quantity (weight variable), switching actual/standard flow with setting parameters 'working pressure' and 'working temperature'
setting parameter with PC software UCOM and programming adapter (see below) may be modified	
* analog end value 20 mA at least 0.7 m/s	

**Functional Safety / Safety Integrity Level (SIL)**

optional according to DIN EN 61508 part 1 to part 7 and DIN EN 61511 part 1 to part 3, SIL2; please pay attention to our document U400!

	Description	Art No.
Appendix: Safety Manual SIL 2 / SC3 (IEC 61508)	U400 SIL label	HBAPPENDIXSIL2

**Accessories (optional)**

	Description	Art No.
ATEX cat. 3G (zone 2)	CE <Ex> II 3 G Ex ec IIC T6 Gc X	VAEX2E
ATEX cat. 3D (zone 22)	CE <Ex> II 3 D Ex tc IIIC TX Dc X	
LCD in housing lid	2 x 16 digit, 3 mm high, working temperature range -5...+60 °C	A010/007
calibration certificate		KLB
PC software UCOM	for config. transducer via RS232	A010/052

Accessories (optional)		
	Description	Art No.
programming adapter GO 070 / RS232	for software UCOM, connection PC Sub-D 9-pin, power plug 230VAC/24VDC	A010/004
interface converter USB / RS232	PC connection : USB plug type A on instrument : Sub-D 9-pin	A010/100
flange DN50 PN16	flange for screwing on to a probe guide piece with outside thread G 1½"	B004/998
piston ring sealing	piston ring sealed with silicone	VA-RINGSPALT

Examples – measurable volume flows (see also under '(5) Measuring range', Page 2)			
measuring tube inside diameter Di [mm]	profile factor PF* [-]	smallest measurable value [m³/h]	terminal value [m³/h]
80	0.719	6.5	520
100	0.738	10.4	835
120	0.761	15.5	1240
150	0.796	26	2030
200	0.842	48	3810
300	0.845	108	8600
400	0.850	193	15400
500	0.860	304	24300
750	0.860	684	54700
1000	0.860	1215	97300
1250	0.860	1900	152000
1500	0.860	2735	218800

Volume flow measuring range specifications with centric positioning of the sensor, irrotational afflux and sufficiently dimensioned input and output section (see Instruction Manual).

\* The profile factor PF describes the ratio of average flow velocity in the measurement cross section and the flow velocity measured from the sensor. The afore-mentioned operating conditions apply.



optional LCD in housing cover

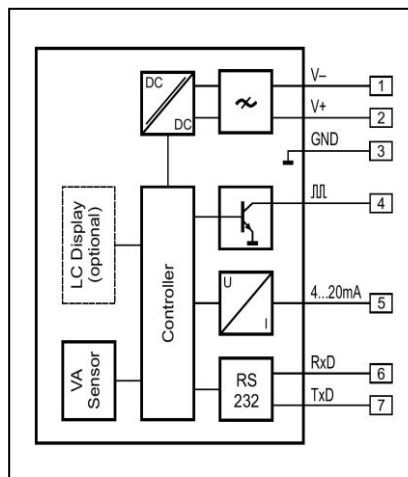

wiring diagram transducer UVA

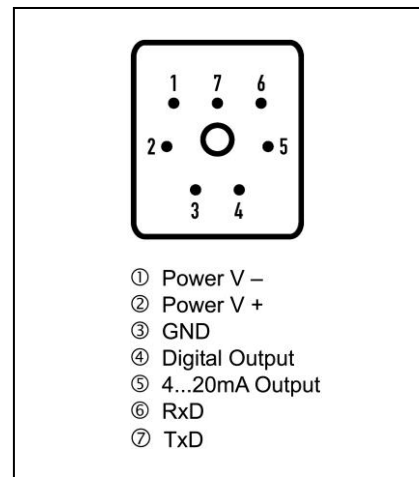

pin configuration plug GO 070

**Höntzsch GmbH & Co. KG**  
 Gottlieb-Daimler-Straße 37  
 D-71334 Waiblingen  
 Telefon +49 7151 / 17 16-0  
 E-Mail info@hoentzsch.com  
 Internet www.hoentzsch.com

Subject to alteration