

Vortex flow sensor VA40 ZG8 Ex-d with integrated, configurable transducer UVA in a flameproof enclosure for applications in explosive atmospheres

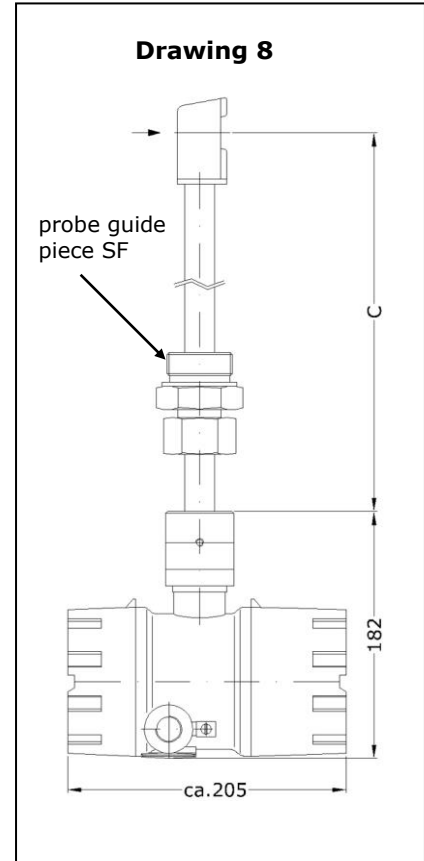

VA40 ZG8 Ex-d with flange guide piece SFB



Probe with screw thread
probe guide piece SF

Measured variables

- actual flow velocity v [m/s]
- actual flow rate [m³/h]
- conversion to standard velocity/standard volume flow with input parameters pressure and temperature

Media

- primarily single-phase gas mixtures with air, nitrogen, oxygen, methane, natural gas, ammonia, argon, carbon monoxide, superheated steam, ... as dominant components; biogas
- Other gases and gas mixtures on request.

Measuring range

- 0.5 ... 40 m/s

Functional principle

- vortex meter for measuring flow velocity, flow rate and volume
- ultrasonic measuring of the vortex shedding



Kármán vortex street

Design

- insertion probe with probe guide piece and flameproof enclosure

Advantages

- compact unit for explosive atmospheres with optional local display
- applications in Category 1 (Zone 0 and 20); transducer housing approved for Category 2 (Zone 1 and 21)
- applications up to SIL2/SC3
- no external isolation/supply unit necessary
- low starting value (0.5 m/s)
- high turndown (1 : 80)
- long-term stability
- no moving parts
- easy to clean
- high durability
- corrosion-resistant
- largely unaffected by gas composition
- marginal pressure loss
- easy adjustment of parameters with HART® interface

Examples of application

- flow measurement in explosive atmospheres: air, outlet air, sludge activation air, engine intake air, natural gas, waste gas, process gas, biogas, car exhaust emissions, flare gas, water vapour, ...

Particles, humidity and condensation

- dust or fibre particles in the gas do not affect the measurement, as long as these are not abrasive or accumulate on the sensor
- measurement uncertainty remains unaffected by a relative gas humidity of less than 100 % and a slight accumulation of condensate on the sensor

Model designation / order code (example)						
VA40	G	E	40 m/s	p3	ZG8	Ex-d
(1)	(2)	(3)	(4)	(5)	(6)	(7)

Types	
Type	Article No.
VA40 GE 40 m/s p3 ZG8 Ex-d	B009/000
VA40 GH 40 m/s p3 ZG8 Ex-d	B009/001
VA40 GT 40 m/s p3 ZG8 Ex-d	B009/002
Optional:	
Design TT (Low Temperature) ambient temperature -40 ... +60 °C	EX-TT

(1) Sensor type / diameter
Vortex flow sensor VA40; width across corners of sensor head 40 mm and shaft \varnothing 21.3 mm for insertion in openings with a diameter greater than 40 mm

(2) Medium	
... G ...	air/gases

(3) Materials in contact with the medium	
Design	Material
... E ...	stainless steel, sensor housing 1.4581 connection tube 1.4404, ceramics silicone-free sensor
... H ...	Hastelloy 2.4610 / HC4, ceramics silicone-free sensor
... T ...	titanium 3.7035 (grade 2), ceramics silicone-free sensor

(4) Measuring range	
Design	Range
... 40 m/s ...	0.5 ... 40 m/s
Measurement uncertainty	< 1.0 % of measured value + 0.03 m/s
Repeatability	\pm 0.2 % of measured value + 0.025 % of terminal value

Examples of measurable flow rates

measuring tube inside diameter Di [mm]	profile factor PF* [-]	smallest measurable value [m³/h]	terminal value [m³/h]
80	0.719	6.5	520
100	0.738	10.4	835
120	0.761	15.5	1240
150	0.796	26	2030
200	0.842	48	3810
300	0.845	108	8600
400	0.850	193	15400
500	0.860	304	24300
750	0.860	684	54700
1000	0.860	1215	97300
1250	0.860	1900	152000
1500	0.860	2735	218800

Flow rate measuring range specifications with centric positioning of sensor, non-rotational (vortex-free) inlet flow and amply dimensioned input/output sections (see Information for use VA Probes U206).

* The profile factor PF describes the ratio of average flow velocity in the measurement cross section and the flow velocity measured from the sensor. The afore-mentioned operating conditions apply.

Working temperature range / seal material

Design	Material	Working temperature range of medium	Article No.
't_{max} +100 °C'			
	FKM	-20 ... +100 °C	B009/080
	silicone	-40 ... +100 °C	B009/081
	EPDM	-40 ... +100 °C	B009/082
	KALREZ® 4079	0 ... +100 °C	B009/083
	KALREZ® 6375	0 ... +100 °C	B009/085
	PFA	-20 ... +100 °C	B009/084
't_{max} +180 °C'			
	FKM	-20 ... +180 °C	B009/090
	silicone	-40 ... +180 °C	B009/091
	EPDM	-40 ... +160 °C	B009/093
	KALREZ® 4079	0 ... +180 °C	B009/092
	KALREZ® 6375	0 ... +180 °C	B009/095
	PFA	-20 ... +180 °C	B009/094
Permissible ambient temperature		-20 ... +60 °C	

(5) Maximum working pressure

up to 3 bar / 300 kPa overpressure

(6) Design

as in Drawing 8 (Page 1)

(7) ATEX protection

for gas : Ⓢ II 1/2 G Ex ia/db eb [ia] IIC T6 Ga/Gb
 for dust : Ⓢ II 1/2 D Ex ia/tb IIIC TX Da/Db
 sensor : Category 1 (Zone 0 or 20)
 transducer housing : Category 2 (Zone 1 or 21)

Installation length (see Drawing 8, Page 1)

Measurement C	stainless steel '... E ...'	Hastelloy '... H ...'	titanium '... T ...'
	Article No.	Article No.	Article No.
250 mm	B009/050	B009/060	B009/070
500 mm	B009/051	B009/061	B009/071
750 mm	B009/052	B009/062	B009/072
1000 mm	B009/053	B009/063	B009/073
1250 mm	B009/054	B009/064	B009/074
1500 mm	B009/055	B009/065	B009/075
1750 mm	B009/056	B009/066	B009/076
2000 mm	B009/057	B009/067	B009/077

Select the installation length so that the surface temperature of the transducer housing does not exceed +50 °C!

Ex-d transducer housing

Dimensions	outside diameter/length/height: ca. 110/205/182 mm
Material	aluminium cast alloy max. 0.5 % Mg, coated
Protection	IP68, IEC 529 and EN 60 529
Connection	glands for shielded cables with outside diameter 5 ... 9 mm; contacting of overall screen on the ground terminal in the housing; via screw terminals Ex-e for wires with cross-section 0.14 – 1.5 mm ²
Alignment	rotatable by approx. 350 ° and lockable
Setup	dual chamber system consisting of: 1) electronics in Ex-d protection (flameproof enclosure) 2) connections in Ex-e protection (increased safety) with terminal block and cable glands

Electromagnetic Compatibility (EMC)

according to EN 61 000-6-2 and EN 61 000-6-4 / IEC77

Functional Safety / Safety Integrity Level (SIL)

optional according to DIN EN 61508 part 1 to part 7 and DIN EN 61511 part 1 to part 3, SIL2; please pay attention to our document U400!

	Description	Art No.
Appendix: Safety Manual SIL 2 / SC3 (IEC 61508)	U400 SIL label	HBAPPENDIXSIL2

Installation position

any	horizontal positioning is recommended if condensate on the sensor cannot be ruled out
-----	---

Probe guid pieces * (see also page 6)		
Designation	Description	Article no.
with screw thread connection		
SFB 21.3 E-53 / G 1 1/2" according drawing 5 (see page 6)	connection: outside thread G 1 1/2" max. pressure: 3 bar / 300 kPa temperature: -20 ... +240 °C materials: stainless steel, FKM, PTFE fixation: clamping bush length: 53 mm thread length: 22 mm	B004/504
SFB 21.3 E-53 / G 1 1/2" with metallic sealing according drawing 5 (see page 6)	connection: outside thread G 1 1/2" max. pressure: 3 bar / 300 kPa temperature: -40 ... +240 °C materials: stainless steel, PTFE fixation: clamping bush length: 53 mm thread length: 22 mm	B004/511
SFB 21.3 E-53 / NPT 1 1/2" according drawing 5 (see page 6)	connection: outside thread NPT 1 1/2" ANSI/ASME B1.20.1-1983 max. pressure: 3 bar / 300 kPa temperature: -20 ... +240 °C materials: stainless steel, FKM, PTFE fixation: clamping bush length: 53 mm thread length: 26 mm	B004/509
with flange connection		
SFB 21.3 E-70 / F-DN50 PN16 according drawing 1 (see page 6)	connection: flange DN50 PN16 EN1092-1 max. pressure: 3 bar / 300 kPa temperature: -40 ... +240 °C materials: stainless steel, PTFE fixation: clamping bush length: 70 mm	B004/103
SFB 21.3 H-70 / F-DN50 PN16 according drawing 1 (see page 6)	connection: flange DN50 PN16 EN1092-1 max. pressure: 3 bar / 300 kPa temperature: -40 ... +240 °C materials: Hastelloy, PTFE fixation: clamping bush length: 70 mm	B004/105
SFB 21.3 E-70 / F-ANSI 2" 150 lb RF according drawing 1 (see page 6)	connection: flange 2" 150 lbs ANSI B16.5 max. pressure: 3 bar / 300 kPa temperature: -40 ... +240 °C materials: stainless steel, PTFE fixation: clamping bush length: 70 mm	B004/512

Probe guide pieces* (cont'd)

Designation	Description	Article No.
with flange connection		
SFK 21.3 E-150 / F-DN50 PN16 according drawing 3 (see below)	connection: flange DN50 PN16 EN1092-1 max. pressure: 6 bar / 600 kPa temperature: -20 ... +240 °C materials: stainless steel, FKM O-ring fixation: clamp yoke length: 150 mm Accessory: hexagon cranked wrench key SW5	B004/304
SFK 21.3 / 42 E-150 / F-DN50 PN16 with ball valve DN50 PN16 similar drawing 3 (see below)	connection: flange DN50 PN16 EN1092-1 max. pressure: 6 bar / 600 kPa temperature: -20 ... +240 °C materials: stainless steel, 2 FKM O-rings fixation: clamp yoke length: 150 mm (ball valve) length: 155 mm (probe guide piece) Accessory: hexagon cranked wrench key SW5 The probe can be retracted into the probe guide piece to close the ball valve.	B004/313

* Probe guide pieces are obligatory for process connection via screw socket or flange connector. They are adjustable, rotatable and permanently attached to the probe shaft. It is to be ensured that sensor length, screw socket or flange connector height as well as probe insertion depth match up. Other probe guide pieces are available on request.

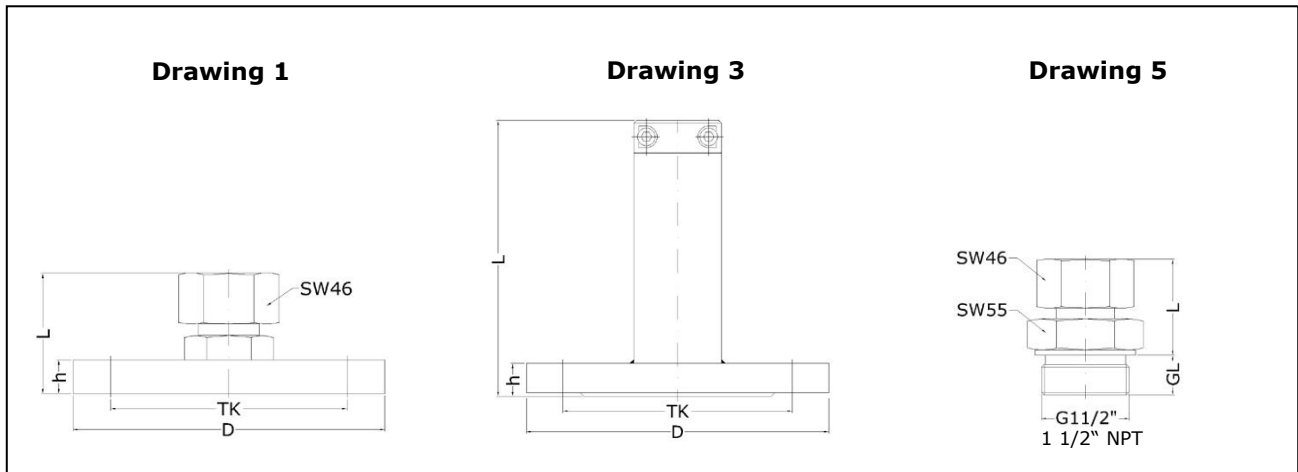

Probe guide pieces SF

Transducer UVA integrated in the connection housing

Analog output flow	4 ... 20 mA resistance max. 500 Ohm
Output limit value or quantity pulse	potential-free relay contact (normally-open), max. 300 mA / 27 VDC
Communication port	HART® via modem adapter for PC connection and UCOM software (see Accessories)
	output signals are electrically isolated from the power supply
Self-monitoring	parameter settings, sensor interface; in the case of error: analog output < 3.6 mA
Power supply	24 V DC (20 ... 27 V DC)
Power consumption	less than 5 W
Setting parameters (selection depending on parameter set)	analog output, time constant, profile factor, tube inside diameter, limit value or quantity pulse (rating adjustable), switchover actual/standard flow with parameters 'working pressure' and 'working temperature'

Accessories (optional)

	Description	Article No.
LCD display	1 st row: 'instantaneous value': flow rate or flow velocity 2 nd row: 'counter' or 'error code' 2 x 16-digit, character height 5.5 mm, working temperature range -20 ... +60 °C display rotatable in 90 °-stages on removing the Ex-d housing window cover	A010/520
Calibration certificate v/VA		KLB
HART® modem adapter	for changing setting parameters, for PC-USB connection	A010/101
PC software UCOM	for configuring the UVA via RS232	A010/052



Ex-d transducer housing
with optional LCD display

Probe installation

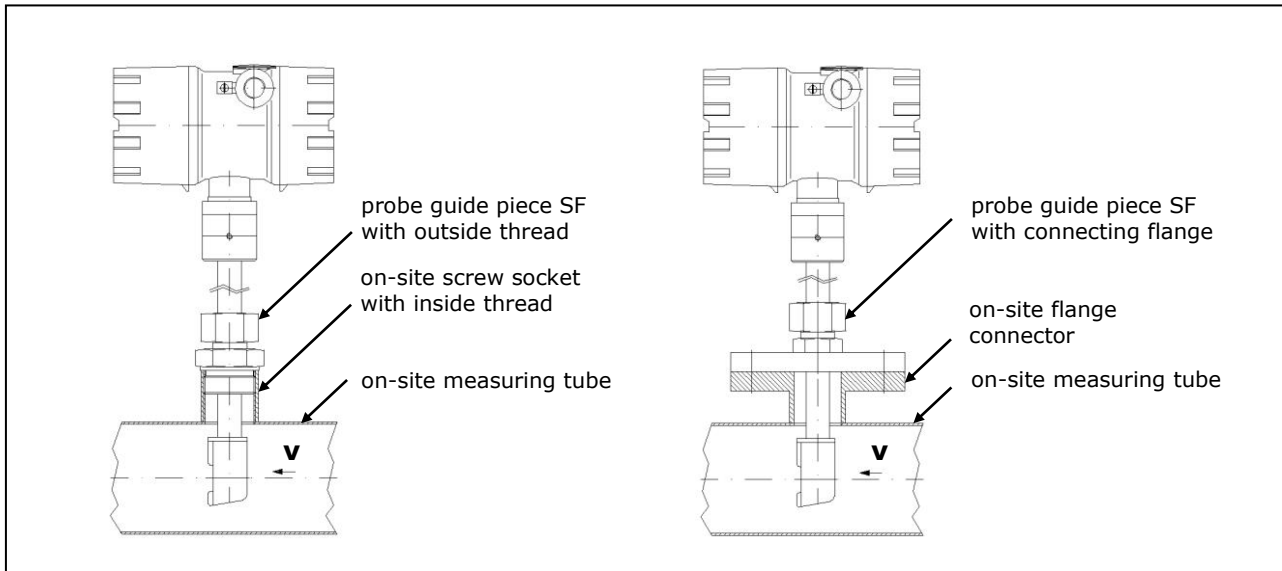

Probe installation with screw thread probe guide piece (left) and flange probe guide piece (right)

Höntzsch GmbH & Co. KG
Gottlieb-Daimler-Straße 37
D-71334 Waiblingen
Telefon +49 7151 / 17 16-0
E-Mail info@hoentzsch.com
Internet www.hoentzsch.com

® Registered trademark:
DuPont: KALREZ;
HART: HART Communication
Foundation

Subject to alteration